

SRWF-1021 Series Low Power Wireless Transceiver Data Module User Manual



ShangHai Sunray Info-tech Co.,Ltd

SRWF-1021 User Manual (V1.3)

I. SRWF-1021 Main Application Range

SRWF-1021, the low-power wireless transceiver data module is used as the wireless data transceiver in short-ranges, with the small size, weight and power consumption and good stability and reliability. Narrowband low power UHF wireless data transmitters and receivers with channel spacings as low as 50 kHz:

- * *AMR – Automatic Meter Reading*
- * *Wireless alarm and security systems*
- * *Home automation*
- * *Low power telemetry*
- * *433/470 / 868 and 915 MHz ISM/SRD band systems*
- * *Data radio can be used for Wireless conference voting system;*
- * *Mapping;*
- * *Radio modem can be used for Sports training & competition;*
- * *Wireless dishes ordering;*
- * *Wireless POS, PDA wireless smart terminal;*
- * *RF modem can be used for Electronic bus station and intelligent traffic;*
- * *RF transmitter Wireless electronic display screen and queuing machine;*
- * *Wireless telemetry Charging for parking, parking lot;*
- * *Wireless modem Automobile inspection and four-wheel orientation;*
- * *Wireless sensor Industrial wireless remote control and air conditioning remote controller;*
- * *Observation and predication of oil well and hydrological information;*
- * *Wireless RS232/RS485 conversion/connector;*
- * *Point to multi-point wireless network, wireless on-the-spot bus and automatic data collection system;*

II. Feature of SRWF-1021 Low Power Data RF Module

- 1. Low power transmission** with the transmission power of 10dBm(433/470MHz), 5dBm(868/915MHz).
- 2. ISM frequency band , requiring on application of frequency point.**
Carrier frequency of 433MHz(SRWF-1021-433),470MHz(SRWF-1021-470), 868MHz(SRWF-1021-868) , 915MHZ(SRWF-1021-915).

3. High anti- interference and low BER(Bit Error Rate)

Based on the GFSK/FSK modulation mode, the high- efficiency forward error correction channel encoding technology is used to enhance data's resistance to both burst interference and random interference and the actual bit error rate of $10^{-5}\sim 10^{-6}$ can be achieved when channel bit error rate is 10^{-2} .

4. Long transmission distance

Within the range of visibility, the reliable transmission distance is >800 m with AT-4 antenna's height greater than 1m (BER= 10^{-3} @433MHz,1200bps).

Within the range of visibility, the reliable transmission distance is >800 m with AT-4 antenna's height greater than 1m (BER= 10^{-3} @470MHz,1200bps).

Within the range of visibility, the reliable transmission distance is >400 m with AT-4 antenna's height greater than 1m (BER= 10^{-3} @868MHz,1200bps).

Within the range of visibility, the reliable transmission distance is >300 m with AT-4 antenna's height greater than 1m (BER= 10^{-3} @915MHz,1200bps).

5. Transparent data transmission

Transparent data interface is offered to suit any standard or nonstandard user protocol. Any false data generated in the air can be filtrated automatically (What has been received is exactly what has been transmitted).

6. Multi- channel

The standard SRWF-1021 configuration provides 8 channels. If the user needs, it can be extended to 16/32 channels, meeting the multiple communication combination mode of the user.

7. Dual serial port, 3 interface modes

SRWF-1021 provides 2 serial ports and 3 interfaces, with COM1 as the TTL level UART interface and COM2 as user defined standard RS-232/RS-485 interface (user only needs to plug/pull 1 bit short circuiter and energize it to make the definition).19200 baud rate only has TTL level UART interface.

8. Large data buffer zone

Interface baud rate is 1200/2400/4800/9600/19200bps with format of 8N1/8O1/8E1/9N1 and user self-definition, allowing the transmission of long data frames at one time for more flexible programming by users. (If the user needs, it can also transmit the data in unlimited length at one time).

9. Intelligent data control and the user doesn't need to prepare excessive programs

Even for semi duplex communication, the user doesn't need to prepare excessive programs, only receiving/transmitting the data from the interface. SRWF-1021 will automatically, complete the other operations, such as transmission/receiving conversion in the air, control, etc.

10. Low power consumption and sleeping function

+5V supply power, receiving current is $28 \pm 2\text{mA}$, transmitting current is $38 \pm 2\text{mA}$, and sleep current is $5 \pm 2\mu\text{A}$.

11. High reliability, small and light

Single chip radio - frequency integrated circuit and single chip MCU are used for lessened peripheral circuits, high reliability, and low false bit rate.

III. Use SRWF-1021 wireless data transceiver module

1. Appearance chart

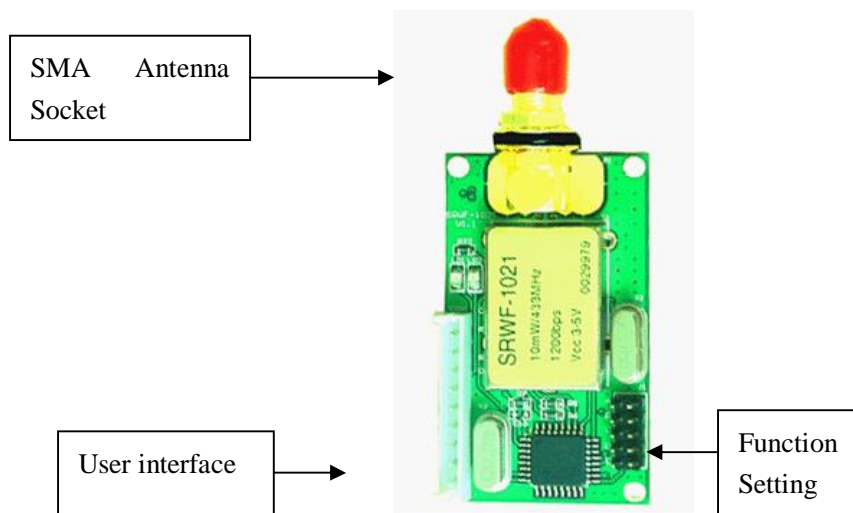

2. Interface definition

SRWF-1021 supply 9- pin connector, and its definitions as well as below. Connection

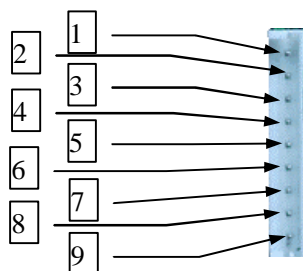

User interface

method for terminals are shown in Table 1.

Table 1

Pin No	Pin Name	Description	Level	Connected to Terminal	Memo
1	GND	Grounding of Power Supply		Grounding of Power Supply	
2	VCC	Power supply DC	+ 3.3 ~ 5.0V		
3	RXD/TTL	Serial data receiving end	TTL	TXD	COM1
4	TXD/TTL	Serial data transmitting end	TTL	RXD	
5	SGND	Grounding of the signal			
6	A(TX)	A of RS-485 Or TX of RS-232		A(RXD)	COM2
7	B(RX)	B of RS-485 or RX of RS-232		B(TXD)	
8	SLEEP	Sleep control (Input)	TTL	Sleep signal	Low level enable t>15ms
9	RESET	Reset control (input)	TTL	Reset signal	Negative pulse reset 1ms

III. Setting of the channel, interface, data rate and data format:

1. Before using SRWF-1021, you have to make simple configuration of your system parameter such as interface and data format.

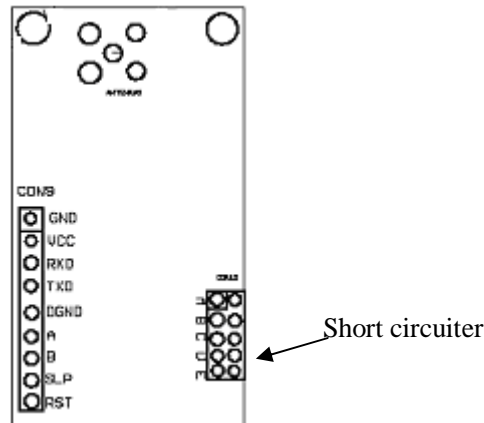









There is one group of 5-bit short-circuiter wire (JP2) on the bottom right corner of SRWF-1021, defined as A、B、C、D、E respectively. Assuming the open circuit of jumper wire (without short circuiter) is mode 1 and short circuit of jumper wire (with short circuiter) is mode 0.

A: channel configuration

ABC jumper wires of JP2 provide 8 options and you can choose to use 0-7 channels .if the work wireless module is work at the same channel (ABC jumper wire mode is same), you can transmit data between each module but keep in mind, at the same time only one module is in TX mode. More detail is Table 3.

Table3

JUMPER ABC	CHANNEL NUMBER	PROGRAM -FREQUENCY (433MHz)	PROGRAM -FREQUENCY (470MHz)	PROGRAM -FREQUENCY (868MHz)	PROGRAM -FREQUENCY (915MHz)
	0(ABC NO SHORT)	433.85	470.25	869.43	915.0
	1	432.10	470.36	869.49	915.2
	2	433.20	470.49	869.56	915.4
	3	433.25	470.10	869.62	915.6
	4	434.00	470.652	867.8	915.8
	5	432.65	470.842	868.0	916.0
	6	433.40	470.90	868.2	916.2
	7	432.60	470.72	868.4	916.4

B: Selection of interface mode

SRWF-1021 provides 2 serial ports. COM1 (Pin3 and Pin4 of JP1) is fixed as UART serial port of TTL level; COM2 (Pin6 and Pin7 of JP1) can choose interface mode through D of JP2:

1. TTL interface connection application circuit.

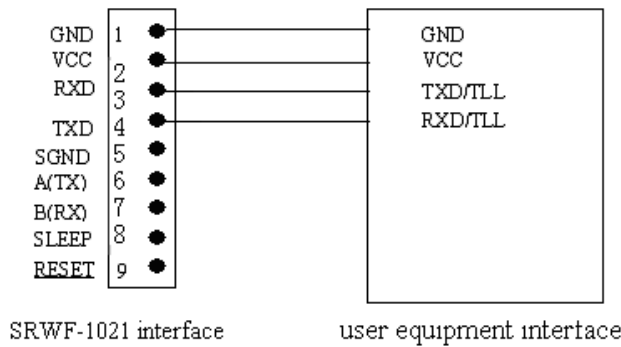

NOTE: Please do not connect any wire on PIN7and PIN8 if com2 is no use

If you use the TTL only please make sure the D jumper of JP2 without jumper wire.

2. RS-232 interface connection application circuit.

D=1(with short jumper as: )

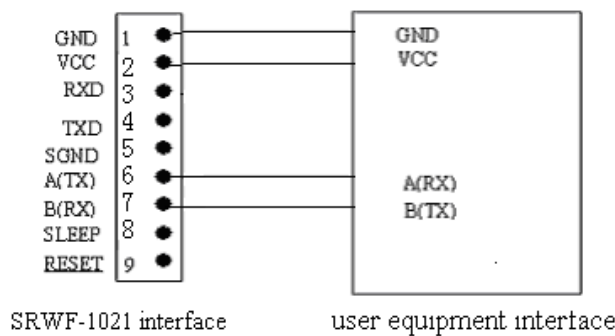

3. RS-485 Interface connection applicati^D circuit.

D=0(without short jumper as: )

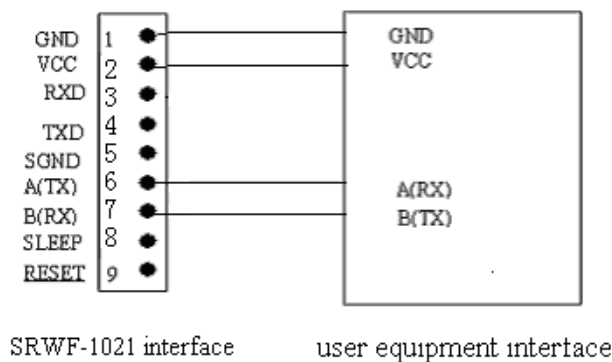

NOTE: Please do not connect any wire on PIN3 and PIN4 if com1 is no use, if the two use different Power supply please make sure the two use the same GND (join the two's GND together).

C: interface rate setting

The rate of SRWF-1021 is determined by hardware; to make sure the module rate is suit to your system, we are must be told your system's rate.

D:SRWF-1021 can support no parity and even parity mode of the serial communication UART it can chose parity mode through E of JP2

E=0 (without short circuiter) parity 8E1/8O1/9N1

E=1 (with short circuiter) parity 8N1

NOTE: channel setting, Com2's Interface mode and parity mode is fixed after the power is on if you want to change the setting, you must reset the module or Power on again.

E:Timing Diagram

(1) The Pin8 'SLP' in JP1 is the signal of sleep control. In low power level, when the transceiver stays in sleep mode, the conversion from idle mode to sleep will be finished in 6ms. If the Sleep signal arrives when the transceiver is transmitting data, the module will enter sleep mode after finishing transmission. From sleep mode to transceiver mode, it takes when the RST signal comes.

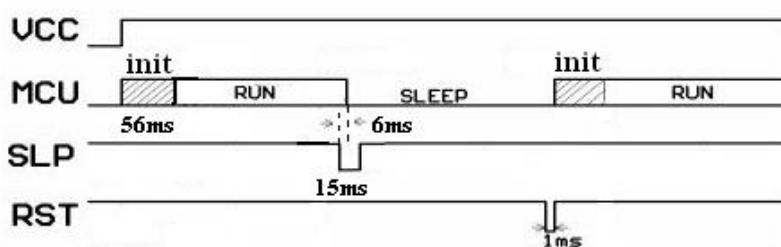

(2)The delay time (Tc) of conversion between transmitting and receiving is less than 3ms.

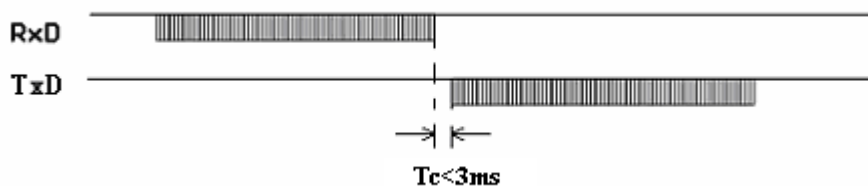

The delay time of transceivers between the first bit sent by TXD to the first bit received by RXD. Due to a data processing will be made on user's data by SRWF-1021 transceiver using FEC(Forward Error Correction) or other correction algorithm, when RXD of a SRWF-1021 transceiver 'A' receives the data, then transmits it, the other one transceiver 'B' will have a delay (Td) to receive and transmit by TXD. Different RF data rate causes different delay time. Please see the

specific delay time below:

Baudrate(bps)	Del ay Time(Td/ms)
1200	122
2400	58
4800	31
9600	16
19200	8



F: indicator fuction

When transmitting mode, the red indicator light will twinkle .(only UART TTL)

When in receiving mode, the green indicator light will twinkle.(only UART TTL)

IV. Technical specification of SRWF-1021:

Serial number	Item	Parameter	Note
1	Modulation mode	GFSK/FSK	
2	Work frequency	433/470/868/915MHz	
3	Transmission power	10dBm(433/470MHz),5dBm(868/915MHz)	
4	Receiving sensitivity	-118 dBm	433MHz@1200bps
		-118 dBm	470MHz@1200bps
		-116 dBm	868MHz@1200bps
		-116 dBm	915MHz@1200bps
5	Channel counts	8channel	16/32 channel custom-made
6	Transmitting current	38±2mA	
7	Receiving current	28±2mA	
8	Sleeping current	5±2uA	-40℃~60℃
9	Interface velocity	1200/2400/4800/9600/19200bps	
10	Interface mode	UART TTL/RS-232/RS-485	User setting, 19200 bps TTL only
11	Power supply	+3.3~5VDC	
12	Working temperature	-25℃~75℃	-40℃~85℃

			custom-made
13	Working humidity	10%~90%(relative humidity without condensation)	
14	Dimension	47mm×26mm×10mm	
15	Reliable transmit distance	800m@ AT-4 antenna	433MHz@1200bps
		800m@ AT-4 antenna	470MHz@1200bps
		400m@ AT-4 antenna	868MHz@1200bps
		300m@ AT-4 antenna	915MHz@1200bps

V.Sketch map of structural size (see below):

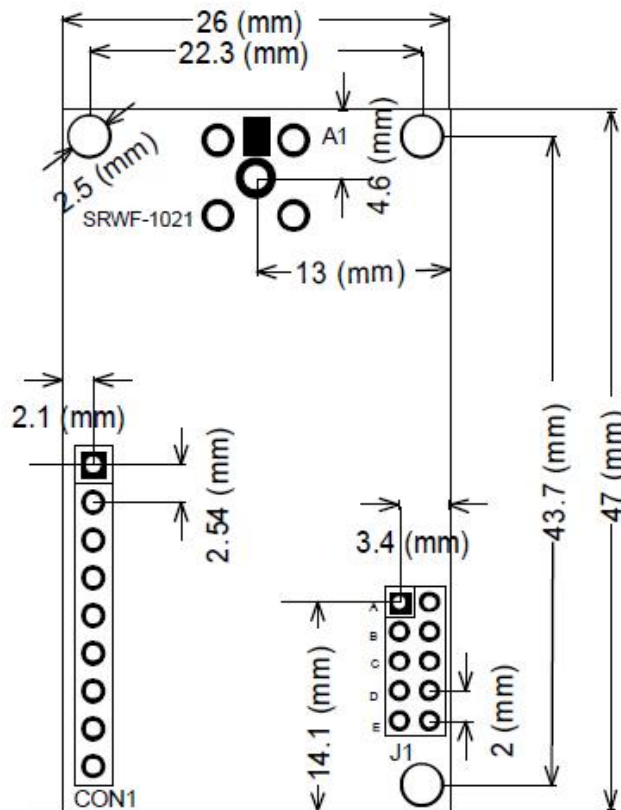



VII. technology support and after service :

We offer sufficient technology support for user use the module and second development for free; mending broken module one year for free, always offer after service.

To adapt different user structure, we can develop smaller module or various size modules

ShangHai Sunray Info-tech Co.,Ltd

**ADDRASS: No 201,Keyuan RD Zhangjiang high-tech park,
Shanghai Pudong china**

Tel:+86-021-50275250/50275255/50273877

Fax:+86-021-50270187

E-mail: sales@tangray.com

Website: www.51sunray.com